

Forno Fusorio Ribaltabile ROL 200

Melting Tilting Furnace ROL 200



Anodes ingot moulds



Carrello lingottiere per anodi



Per fondere leghe, metalli preziosi e non ferrosi, ceneri di pulimenti e spazzature, anodi, etc. ad elevate temperature ed in quantità medio - grandi.

Oggi ancora più rapidi, affidabili e sicuri grazie ai comandi di ribaltamento e discesa a distanza con velocità variabile ed all'alimentazione combustibile attraverso giunto girevole ad evitare tubazioni flessibili di collegamento al bruciatore.

Sistema di ribaltamento oleodinamico funzionante a bassa pressione ed in asse rispetto al becco di colata.

Perfect for melting highest temperature middle-high volumes of different materials like alloys, precious and not ferrous metals, residual ashes from polishing and floor sweepings, anodes, etc.

Today the ROL series is even more rapid, reliable and safe thanks to the tilting and lowering commands activated via remote control, by which it's also possible to regulate the movement speed. Besides, a swivel assures the fuel to the system avoiding any need for flexible pipes for the connection to the burner.

ROL200 is a tilting low-pressure hydraulic system alligned with the pouring spout

Forno Fusorio Ribaltabile ROL 200

Melting Tilting Furnace ROL 200



CROGIOLO A.200
CRUCIBLE A.200

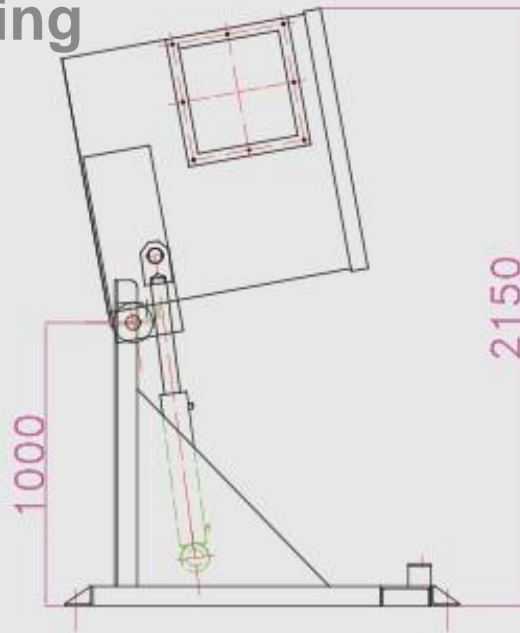

*Ingombri bruciatore in funzione di modello e combustibile
Burner's dimensions in function of type and feeding*

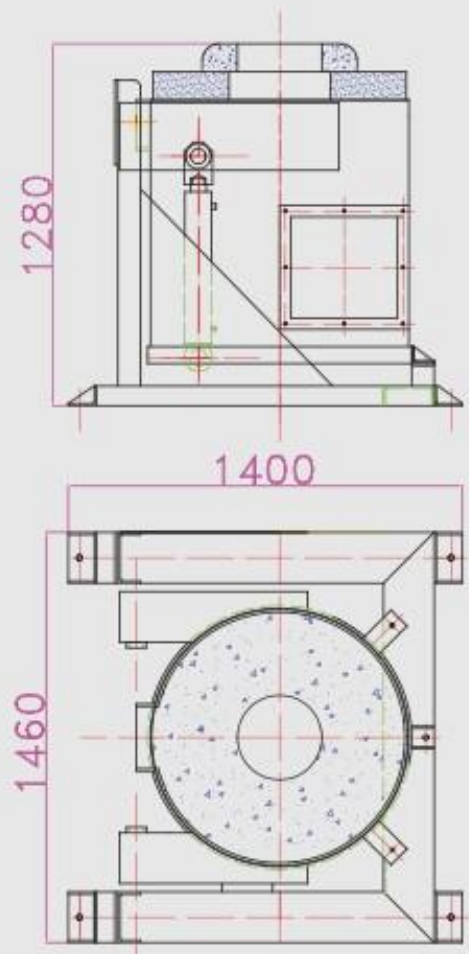

Caratteristiche principali
Peso complessivo: Kg. 1350
Potenza elettrica: a partire da KW 1,5
Potenzialità termica: > 150.000 Kcal/h
Standard applicati: CE
Consumi CH4: > 17,7 Nmc/h
Consumi GPL: > 12,5 Kg/h
Capacità max crogiolo: A.200

Main features
*Total weight: Kgs. 1350
Electric power: from KW 1,5
Max thermal power: > 150.000 Kcal/h
Standards: CE
CH4 consumption: > 17,7 Nmc/h
LPG consumption: > 12,5 Kgs/h
Max crucible capacity: A.200*